

PRODUCT INFORMATION
CANNED MOTOR PUMP TYPE CAM / CAMR

REFRIGERATION ENGINEERING

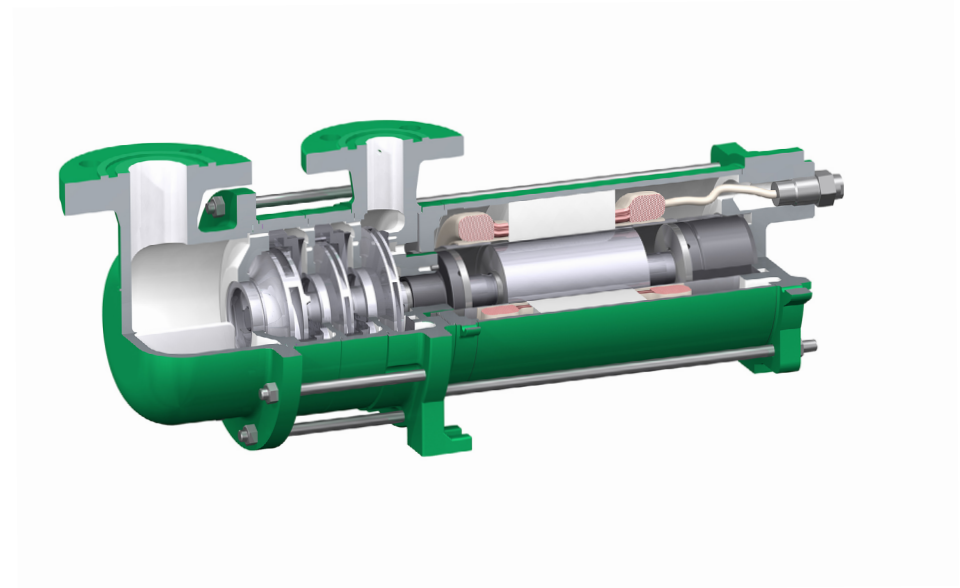
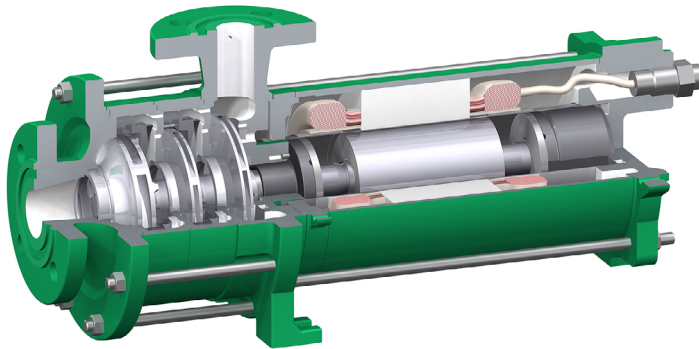

ZART®

simply best balance

Information

Operating data

Temperature

Areas of application -50 °C to +30 °C

Canned motors

Output	up to 25.0 kW
Speed	2800 rpm or 3500 rpm (frequency control possible – with frequency converter from 1500 rpm to 3500 rpm)
Voltage	230, 400, 480, 500, 575, 690 Volt
Frequency	50 Hz or 60 Hz
Type of protection	IP 55

Pump and hydraulics designations

CAM 2 / 3 AGX 3.0

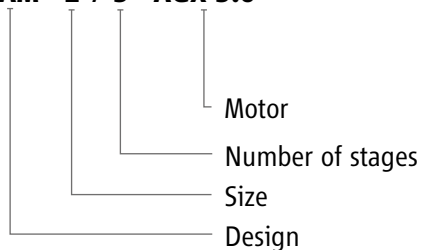

Table of Contents

General information

Function

Operating principle

Characteristic maps

Versions

CAM 1 / CAM 2

CAMR 2

CAM 3

Documentation and tests

Installation

Protection and monitoring

Flow regulation

Design software

Contact



CAM function

The partial flow for cooling the motor and lubricating the bearing is taken from the pressure side after the last impeller and passed through the motor chamber. The partial flow is not returned to the suction side of the pump through the hollow shaft but to an area with increased pressure between two impellers. Therefore, point 3 in the pressure-temperature diagram that corresponds to the greatest heating has sufficient distance from the vapour pressure curve to prevent gasification within the pump.

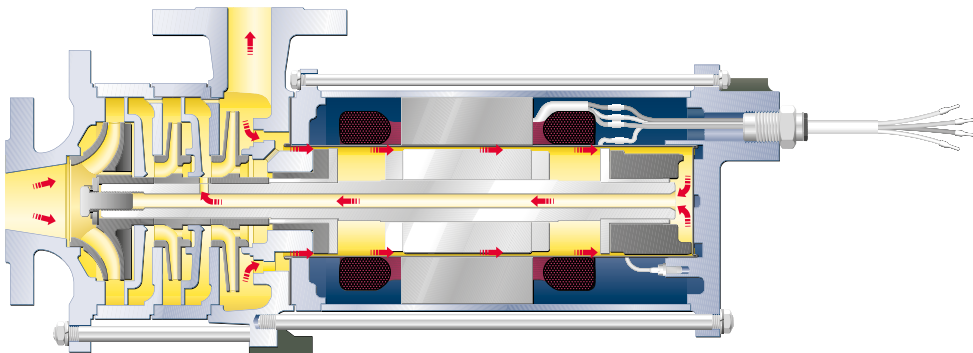

Partial flow return between the stages

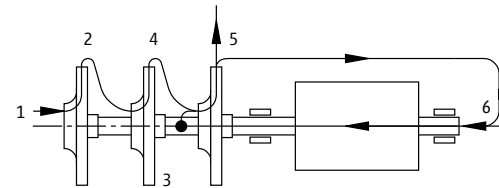

Pressure-temperature diagram

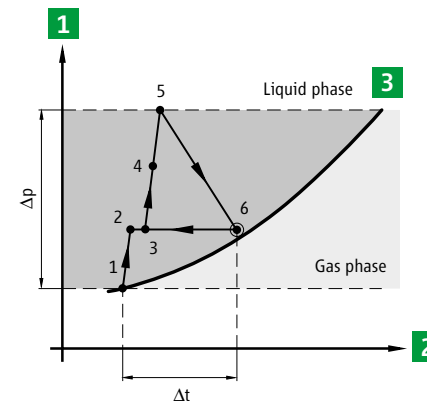

- 1 Pressure
- 2 Temperature
- 3 Vapour pressure curve

Table of Contents

General information

Function

Operating principle

Characteristic maps

Versions

CAM 1 / CAM 2

CAMR 2

CAM 3

Documentation and tests

Installation

Protection and monitoring

Flow regulation

Design software

Contact



2900 rpm 50 Hz

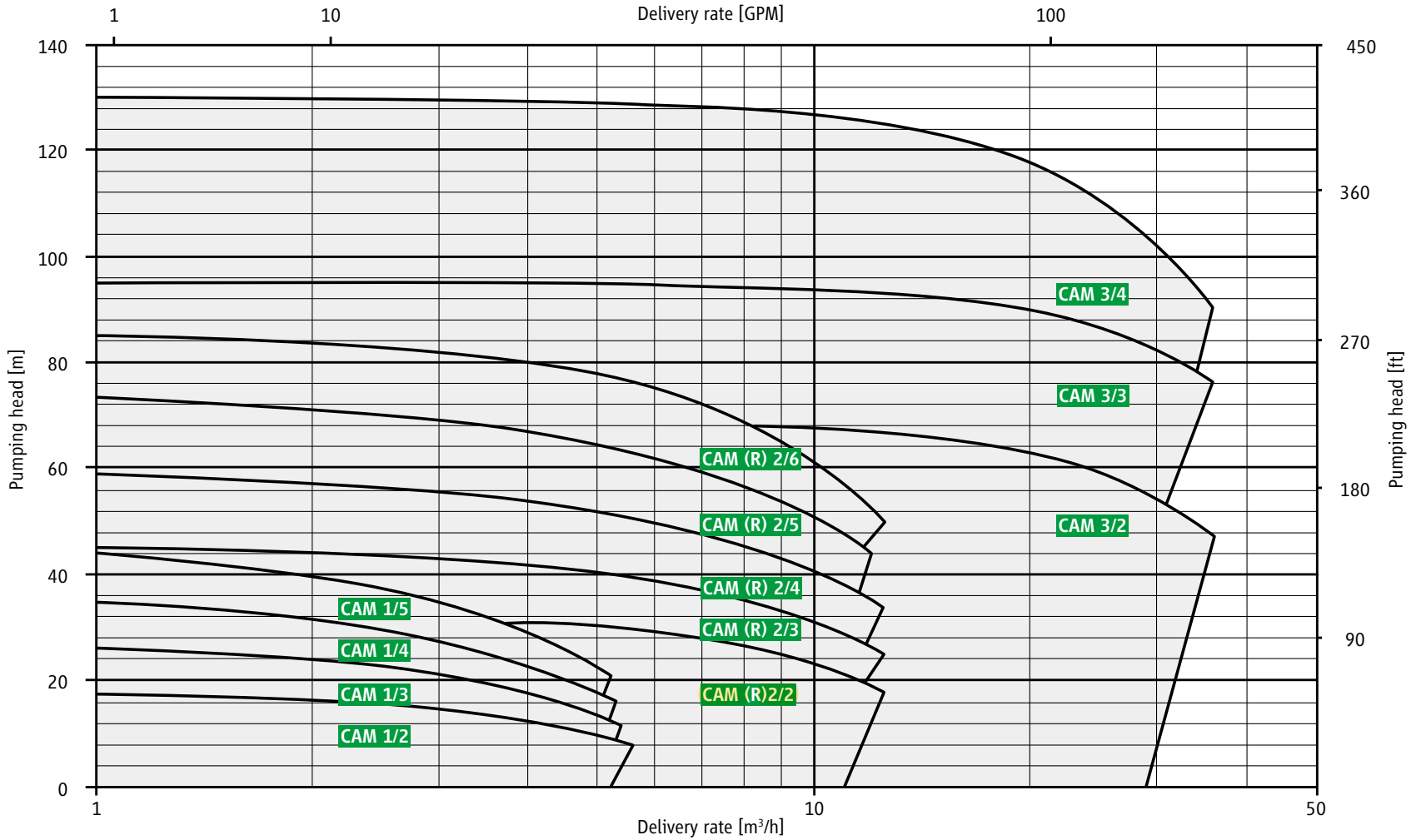

- Table of Contents
- General information
- Function
- Operating principle
- Characteristic maps**
- Versions
- CAM 1 / CAM 2
- CAM R 2
- CAM 3
- Documentation and tests
- Installation
- Protection and monitoring
- Flow regulation
- Design software
- Contact



3500 rpm 60 Hz

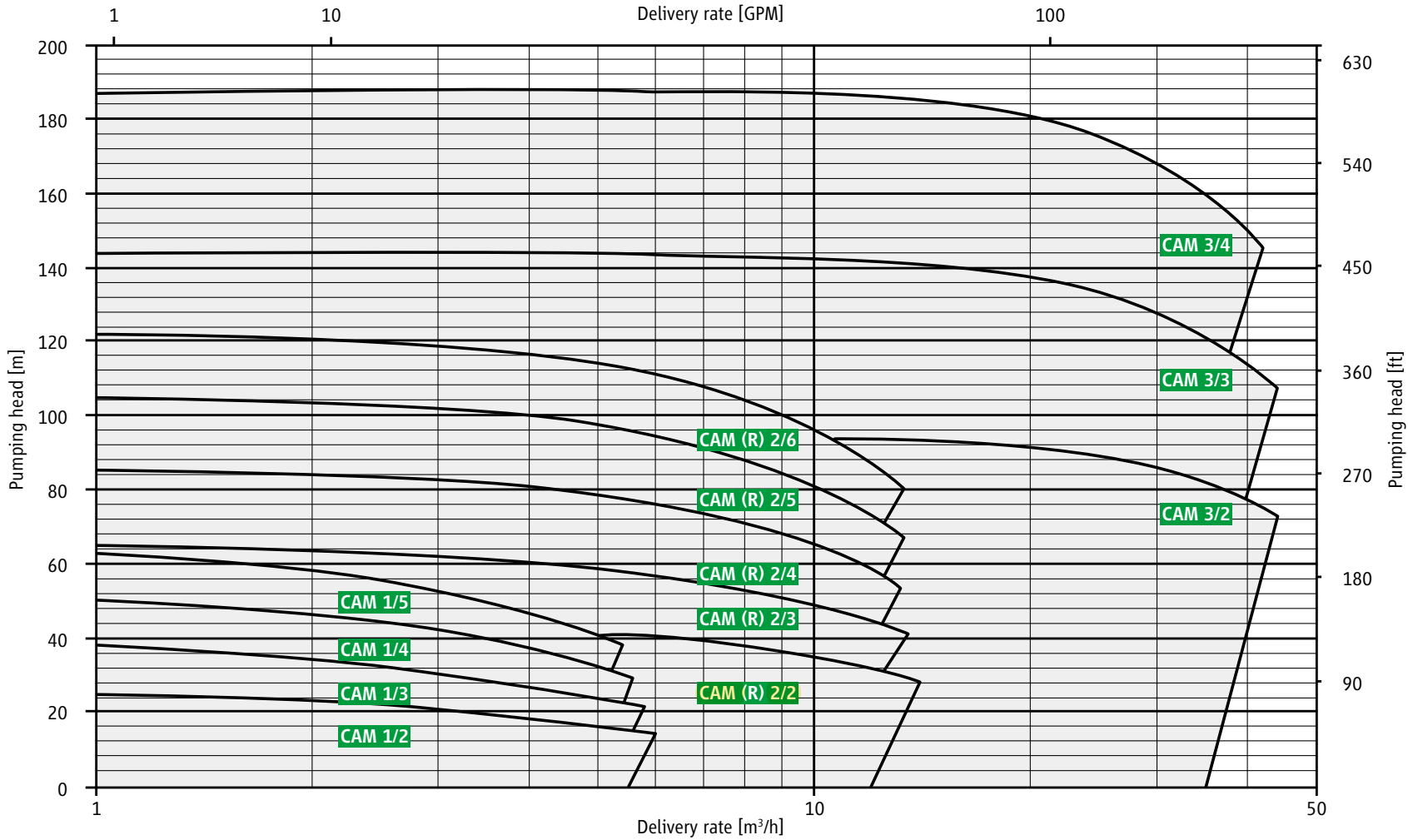

- Table of Contents
- General information
- Function
- Operating principle
- Characteristic maps**
- Versions
- CAM 1 / CAM 2
- CAM R 2
- CAM 3
- Documentation and tests
- Installation
- Protection and monitoring
- Flow regulation
- Design software
- Contact



Versions CAM / CAMR

Type	Motor	Pump data		Motor data 50 Hz / 60 Hz		Weight kg	PN
		Q _{min} m ³ /h	Q _{max} m ³ /h	Output kW [P2]	Rated current at 400 V / 480 V		
CAM 1/2	AGX 1.0	0.5	5.0	1.0 / 1.2	2.7	27.0	40
CAM 1/3	AGX 1.0	0.5	5.0	1.0 / 1.2	2.7	28.0	40
CAM 1/4	AGX 1.0	0.5	5.0	1.0 / 1.2	2.7	29.0	40
CAM 1/5	AGX 1.0	0.5	5.0	1.0 / 1.2	2.7	30.0	40
CAM (R) 2/2	AGX 3.0	1.0	13.0	3.0/3.4	7.1	48.0	40
CAM (R) 2/2	AGX 4.5	1.0	14.0	4.5 / 5.6	10.4	56.0	40
CAM (R) 2/3	AGX 3.0	1.0	13.0	3.0 / 3.4	7.1	52.0	40
CAM (R) 2/3	AGX 4.5	1.0	14.0	4.5 / 5.6	10.4	60.0	40
CAM (R) 2/3	AGX 6.5	1.0	14.0	6.5 / 7.5	15.2	63.0	40
CAM (R) 2/4	AGX 3.0	1.0	14.0	3.0 / 3.4	7.1	56.0	40
CAM (R) 2/4	AGX 4.5	1.0	14.0	4.5 / 5.6	10.4	68.0	40
CAM (R) 2/4	AGX 6.5	1.0	14.0	6.5 / 7.5	15.2	71.0	40
CAM (R) 2/5	AGX 3.0	1.0	14.0	3.0 / 3.4	7.1	60.0	40
CAM (R) 2/5	AGX 4.5	1.0	14.0	4.5 / 5.6	10.4	74.0	40
CAM (R) 2/5	AGX 6.5	1.0	14.0	6.5 / 7.5	15.2	77.0	40
CAM (R) 2/6	AGX 3.0	1.0	14.0	3.0 / 3.4	7.1	64.0	40
CAM (R) 2/6	AGX 4.5	1.0	14.0	4.5 / 5.6	10.4	78.0	40
CAM (R) 2/6	AGX 6.5	1.0	14.0	6.5 / 7.5	15.2	81.0	40
CAM 3/2	AGX 8.5	6.0	30.0	8.5 / 9.7	19.0	120.0	40
CAM 3/2	CKPx 12.0	6.0	30.0	13.5 / 15.7	31.0	150.0	25 / 40
CAM 3/3	AGX 8.5	6.0	30.0	8.5 / 9.7	19.0	138.0	40
CAM 3/3	CKPx 12.0	6.0	30.0	13.5 / 15.7	31.0	168.0	25 / 40
CAM 3/3	CKPx 19.0	6.0	30.0	22.0 / 25.0	49.5	213.0	25 / 40
CAM 3/4	CKPx 12.0	6.0	35.0	13.5 / 15.7	31.0	186.0	25 / 40
CAM 3/4	CKPx 19.0	6.0	35.0	22.0 / 25.0	49.5	231.0	25 / 40

Table of Contents

General information

Function

Operating principle

Characteristic maps

Versions

CAM 1 / CAM 2

CAMR 2

CAM 3

Documentation and tests

Installation

Protection and monitoring

Flow regulation

Design software

Contact



Materials / pressure stages / flanges

Housing	JS 1025
Suction cover (suction housing CAMR 2)	JS 1025
Stage casing (CAM 1, CAM 2, CAMR 2)	1.0460
Stage casing (CAM 3)	JS 1025
Diffuser (guide wheel CAM 3)	JL 1030
Impellers	JL 1030
Slide bearing	1.4021 / carbon
Shaft	1.4021
Rotor lining	1.4571
Seals	AFM 34*
Pressure rating	PN 40**, PN 25 (for motors CKPx 12.0 and CKPx 19.0)
Flanges	according to DIN EN 1092-1, PN 40 and PN 25 type D

* asbestos-free aramid fibre, ** test pressure 60 bar

Noise expectancy values

Motors	AGX 1.0	AGX 3.0	AGX 4.5	AGX 6.5	AGX 8.5	CKPx 12.0	CKPx 19.0
Output power [P2 at 50 Hz]	1.0 kW	3.0 kW	4.5 kW	6.5 kW	8.5 kW	13.5 kW	22.0 kW
max. expected sound pressure level dB(A) at 50 Hz	48	52	54	56	57	59	61
Output power [P2 at 60 Hz]	1.2 kW	3.4 kW	5.6 kW	7.5 kW	9.7 kW	15.7 kW	25.0 kW
max. expected sound pressure level dB(A) at 60 Hz	48	52	55	56	57	59	61

Table of Contents

General information

Function

Operating principle

Characteristic maps

Versions

CAM 1 / CAM 2

CAMR 2

CAM 3

Documentation and tests

Installation

Protection and monitoring

Flow regulation

Design software

Contact



List of parts CAM 1 / CAM 2

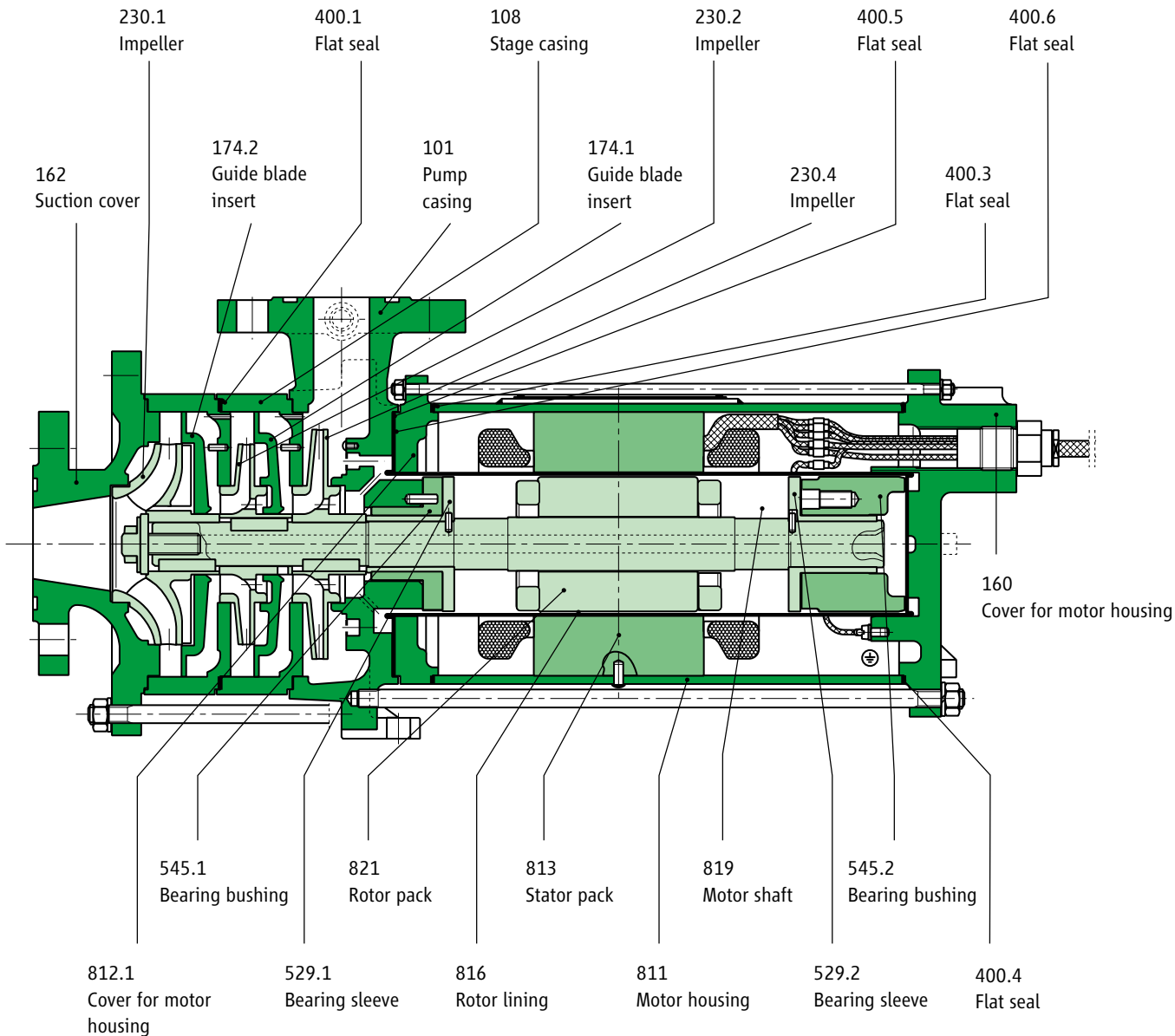

- Table of Contents
- General information
- Function
- Operating principle
- Characteristic maps
- Versions
- CAM 1 / CAM 2**
- CAMR 2
- CAM 3
- Documentation and tests
- Installation
- Protection and monitoring
- Flow regulation
- Design software
- Contact

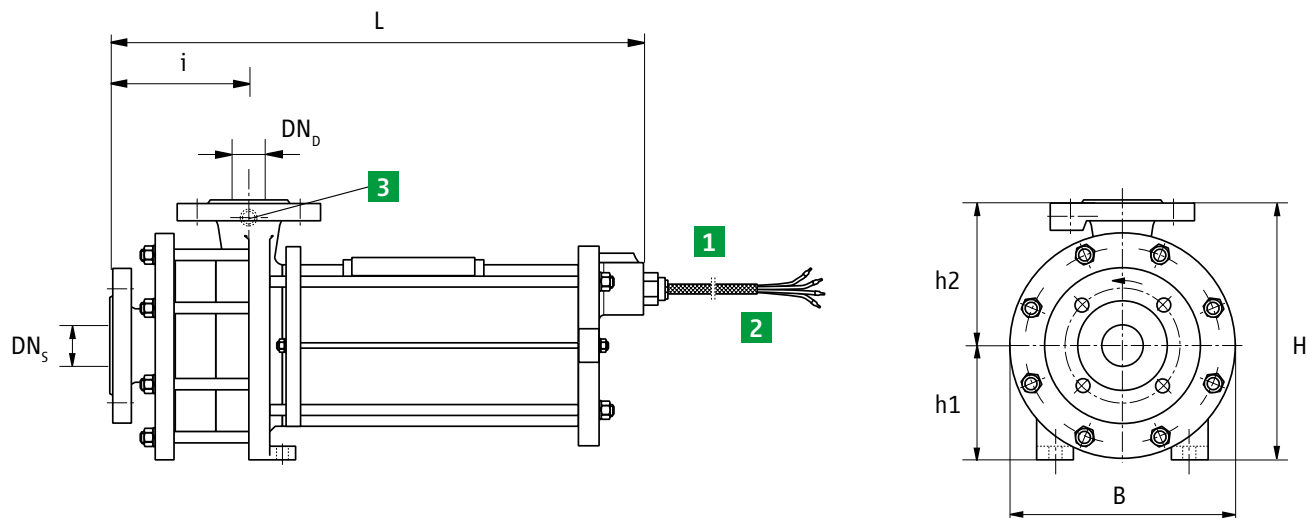

Dimension drawing for motors of size: AGX 1.0 / AGX 3.0 / AGX 4.5 / AGX 6.5

- | | |
|---|--|
| 1 Cable U1, V1, W1 + protective conductor \oplus | 2 Cable for PTC thermistor |
| AGX 1.0: 4 x 1.5 mm ² | 2 x 1.0 mm ² , cable 5 + 6, |
| AGX 3.0: 4 x 1.5 mm ² | Cable length 2.5 m |
| AGX 4.5: 4 x 2.5 mm ² | 3 Pressure gauge connection G 1/4 |
| AGX 6.5: 4 x 4 mm ² | |
| Cable length 2.5 m | |

[Table of Contents](#)
[General information](#)
[Function](#)
[Operating principle](#)
[Characteristic maps](#)
[Versions](#)
[CAM 1 / CAM 2](#)
[CAMR 2](#)
[CAM 3](#)
[Documentation and tests](#)
[Installation](#)
[Protection and monitoring](#)
[Flow regulation](#)
[Design software](#)
[Contact](#)

Versions CAM 1

Dimensions	CAM 1 / 2-stage	CAM 1 / 3-stage	CAM 1 / 4-stage	CAM 1 / 5-stage
	AGX 1.0	AGX 1.0	AGX 1.0	AGX 1.0
Length / L	419	447	475	503
Width / W	160	160	160	160
Height / H	10	210	210	210
h1	90	90	90	90
h2	120	120	120	120
i	112	140	168	196
DN _s	25	25	25	25
DN _b	20	20	20	20

Versions CAM 2

Dimensions	CAM 2 / 2-stage	CAM 2 / 3-stage	CAM 2 / 4-stage	CAM 2 / 5-stage	CAM 2 / 6-stage
	AGX 3.0 / 4.5	AGX 3.0 to 6.5	AGX 3.0 to 6.5	AGX 3.0 to 6.5	AGX 3.0 to 6.5
Length / L	536	577	618	659	700
Width / W	218	218	218	218	218
Height / H	250	250	250	250	250
h1	110	110	110	110	110
h2	140	140	140	140	140
i	135	176	217	258	299
DN _s	40	40	40	40	40
DN _b	32	32	32	32	32

Table of Contents

General information

Function

Operating principle

Characteristic maps

Versions

CAM 1 / CAM 2

CAMR 2

CAM 3

Documentation and tests

Installation

Protection and monitoring

Flow regulation

Design software

Contact

